

**VDC2211 NF SATI**  
**VDC2211 PF SATI**  
**VDC2211 LSC**



+ EC03xx  
 + TCB2211  
 + TCN2211



+ AMB22 VDC  
 + AMN22 VDC

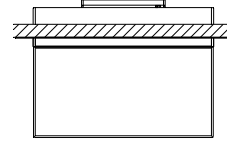

+ APB VDC  
 + APN VDC

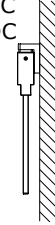

+ ASB VDC  
 + ASN VDC

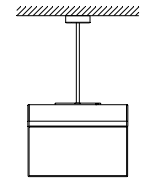

**1**

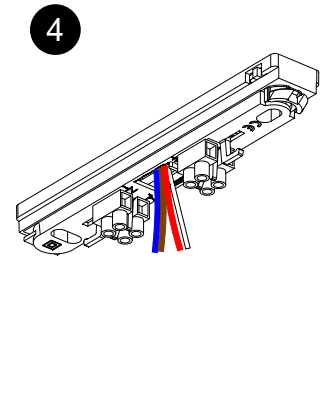
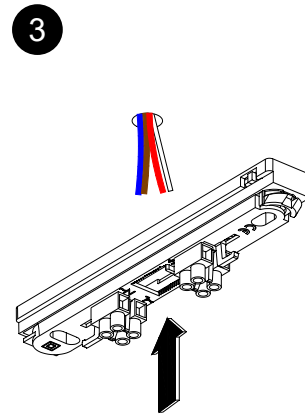
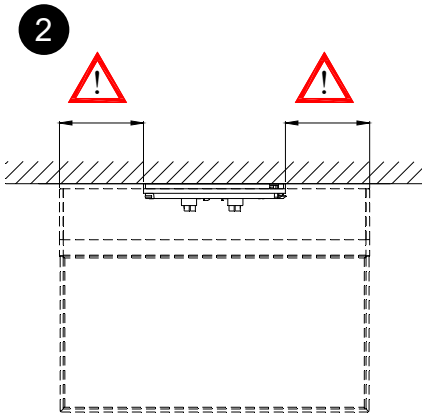
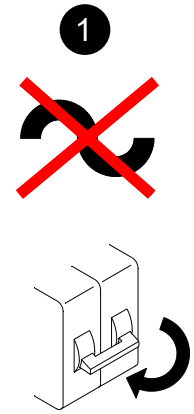

**2**

**VDC2211 NF SATI**  
**VDC2211 PF SATI**

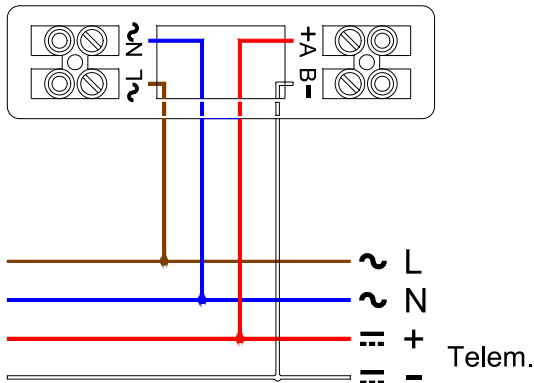

**VDC2211 LSC**

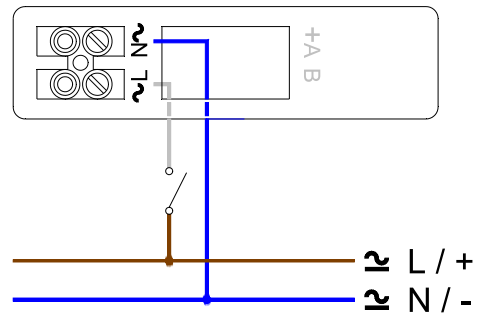

**3**

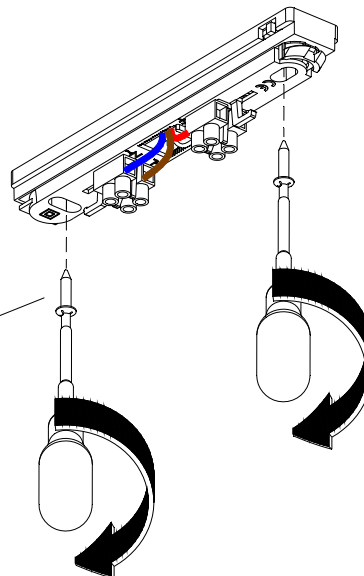
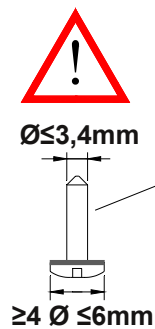

EC03xx



VDC2211...

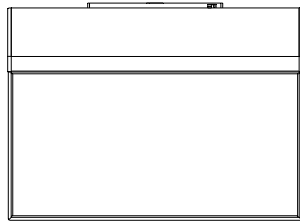

TCx2211



4

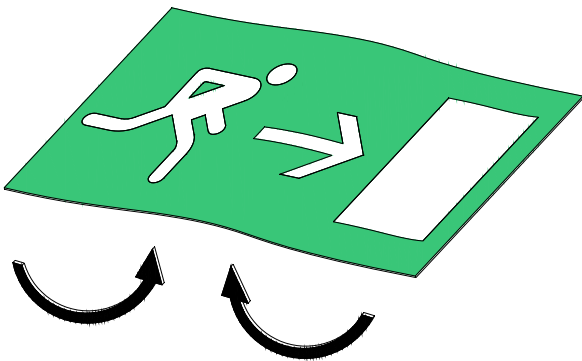

5

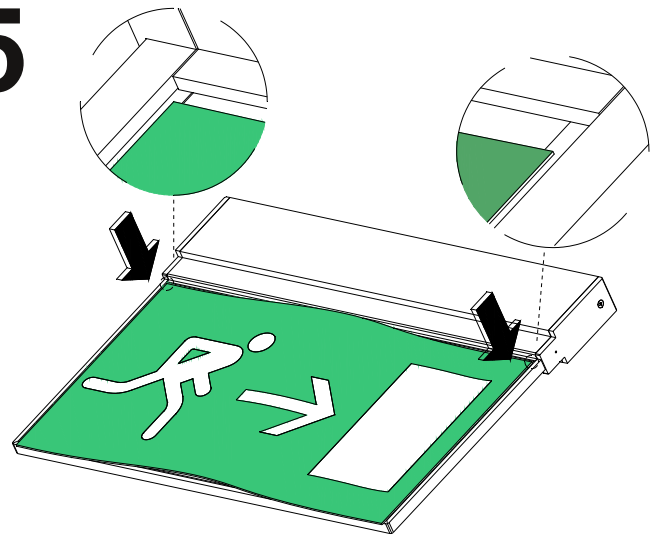

6

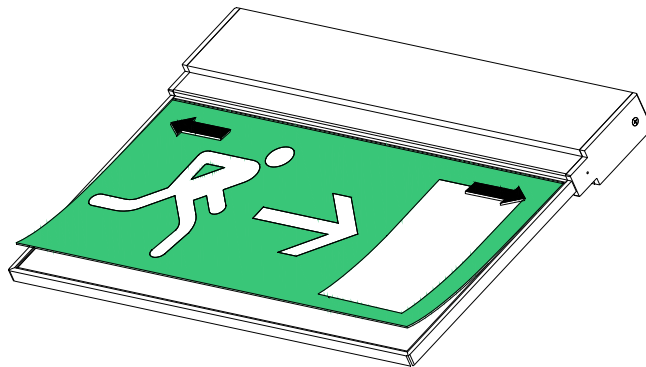

7

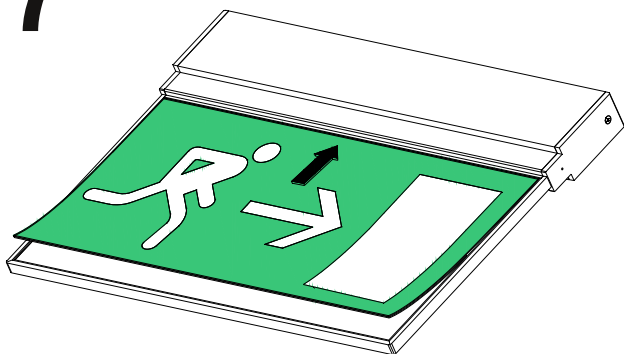

8

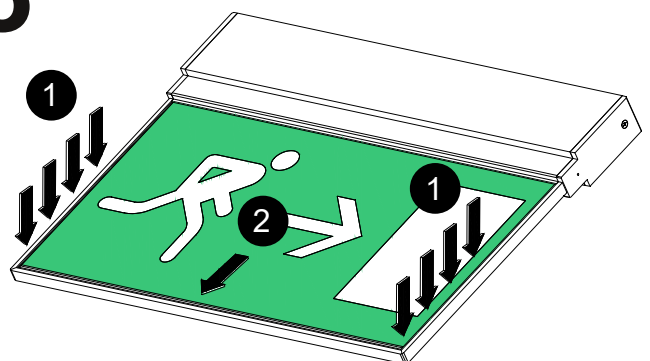

# 9

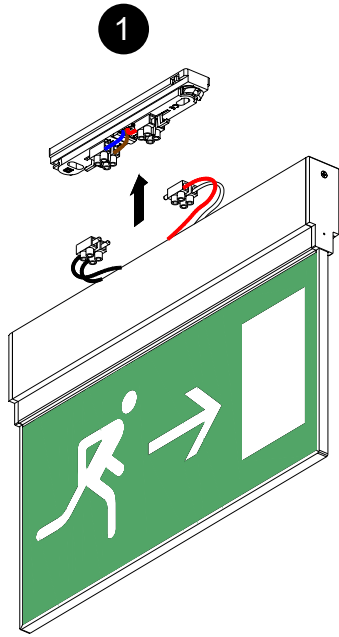

## 2

VDC2211 NF SATI  
VDC2211 PF SATI

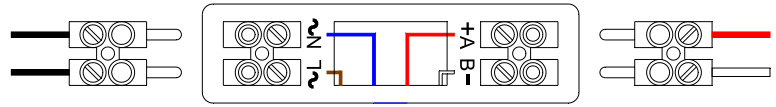

VDC2211F LSC

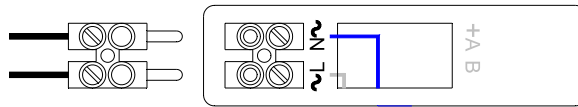

# 10

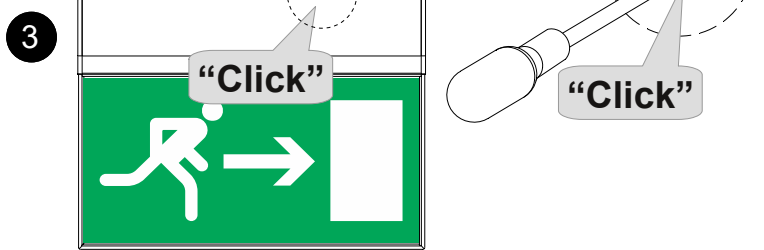

# 11

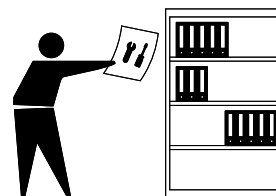
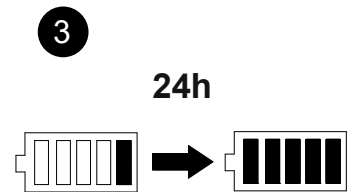
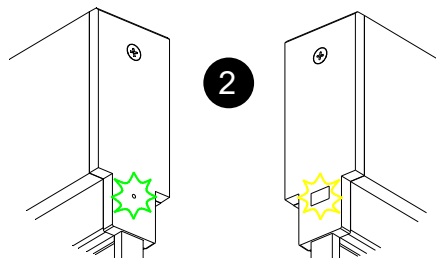
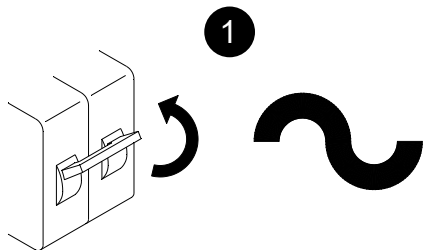

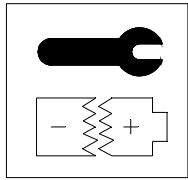

1

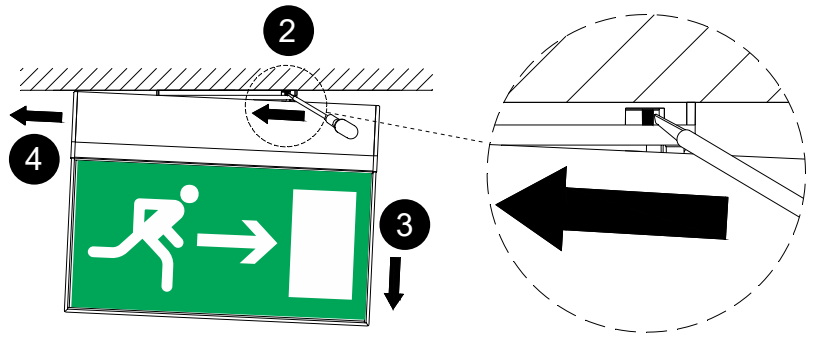
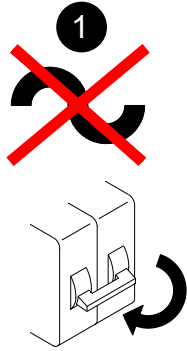

2

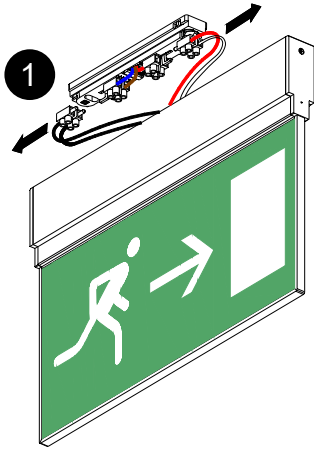

2

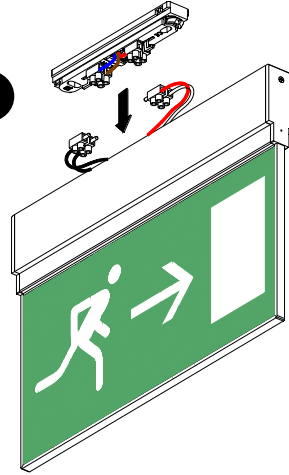

3

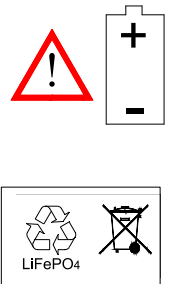
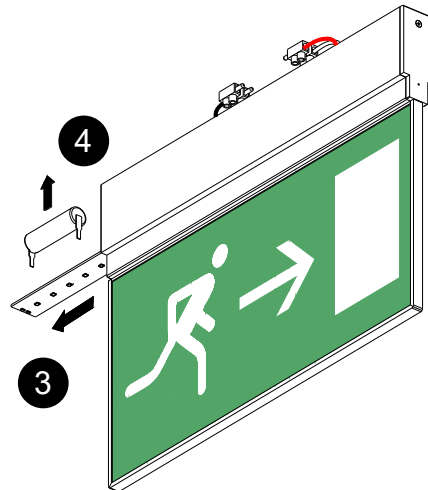
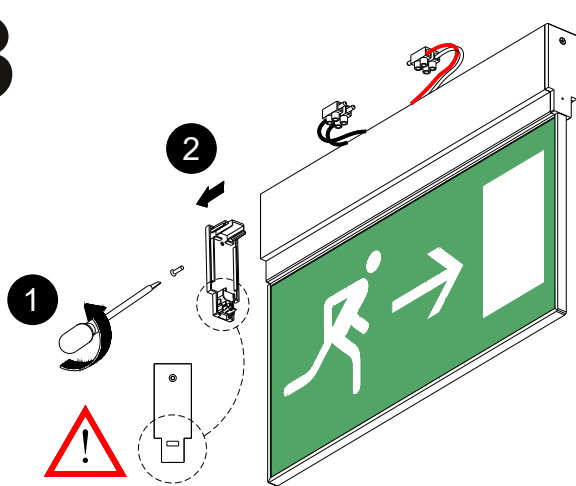

1

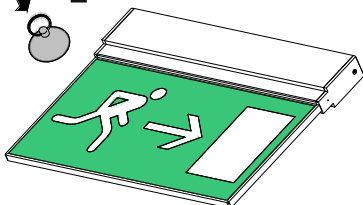

2

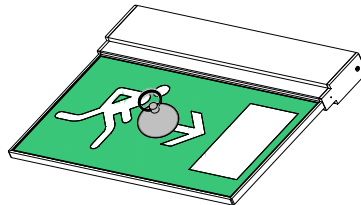

3

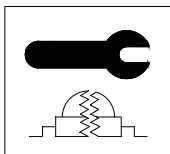
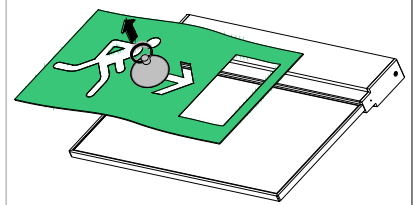

**ES** La fuente de luz sólo puede ser reemplazada por el fabricante o personal cualificado.  
**DE** Die Lichtquelle darf nur vom Hersteller oder von qualifiziertem Personal Ausgetauscht werden.  
**IT** La sorgente luminosa può essere sostituita soltanto dal produttore o da personale qualificato.  
**NL** De lichtbron mag enkel door de fabrikant of door erkende vaklui vervangen worden.  
**PL** Źródło światła może być wymieniane tylko przez producenta lub wykwalifikowany personel.

**EN** The light source may only be replaced by the manufacturer or qualified personnel.  
**FR** La source de lumière peut uniquement être remplacée par le fabricant ou par du personnel qualifié.  
**PT** A fonte de luz só pode ser substituída pelo fabricante ou pessoal qualificado.  
**RU** Источник света может быть заменен только изготовителем или квалифицированными специалистами.

عربية لا يمكن استبدال مصدر الضوء إلا من قبل المنتج أو موظف مؤهل.